

**NOTICE INVITING TENDER (NIT) FOR FURNISHING OF
COMPUTATION LAB AND COMPUTER ARCHITECTURE LAB AT
WORKSHOP 3, TRANSIT CAMPUS**

Tender No. IITPKD/EWD/MB/053/2019-20

Date/Time of Publication: 25-10-2019, 1500 hours

Date/Time of Closing: 14-11-2019, 1500 hours

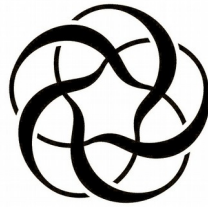

IIT PALAKKAD

Indian Institute of Technology Palakkad
Ahalia Integrated Campus, Kozhipara,
Palakkad – 678 557.

GENERAL

1.1. Indian Institute of Technology Palakkad (herein after called "IITPKD") invites sealed Tenders under Two-Bid System for **Furnishing of Computational Imaging and Computer Architecture Lab at Workshop-3, Transit Campus, IIT Palakkad** as per the specifications given in **Annexure-I**.

1.2. The tender documents may be obtained from the Office of the Registrar, IIT Palakkad, Ahalia Integrated Campus, Kozhipara, Palakkad-678557 or downloaded from <https://iitpkd.ac.in/tenders> or <https://eprocure.gov.in/cppp/>. Last date/time for submission of the bids is **14-11-2019, 1500 hours**. The bids will be opened by the duly constituted Committee in the presence of the bidders or their authorized representatives, who wish to be present on the same day at **1700 hours**. The bidder's representative should carry authorization letter from their company empowering them to participate in the pre-bid and tender opening meetings. The technical bids will be opened and examined by a technical committee, which will decide the suitability of the bid as per the specifications and requirements of IITPKD. In respect of opening of financial bids, those bidders who are technically qualified only will be called. In case of any holiday or unforeseen closure of the institute on the scheduled day of opening of the bids, the bids will be opened on the next working day at the same time, but the deadline for submission of bids remains the same as indicated above. Supply/Download of tender documents will close on the last working day at 1500 hours before the last date for submission of the tenders.

1.3. The bids shall reach **Registrar, IIT Palakkad, Ahalia Integrated Campus, Kozhipara, Palakkad-678557**, by Post/Courier/in person latest **by 14-11-2019, 1500 hours**. Bids received after the abovementioned date and time shall not be considered. Bids sent through Cable/Facsimile/Email/FAX/any other mode shall not be considered. Conditional bids will be rejected outright. The tender box is kept in the office of the Academic Block, IIT Palakkad, Ahalia Integrated Campus, Kozhipara, Palakkad-678 557.

1.4. The responsibility of submission of the bids on or before the last date shall rest with the tenderer. The institute will hold no responsibility for the non-receipt of the bids or for the bids received after the date/time specified. Any bid received by IITPKD after the bid submission deadline prescribed by IITPKD, shall be rejected and returned unopened to the Bidder.

1.5. The timeline for the NIT is as mentioned below:

S. No.	Events	Date and Time
1	Publication of the Tender Document	25-10-2019, 1500 hours
2	Last date for submission of sealed tenders	14-11-2019, 1500 hours
3	Opening of Technical Bids	14-11-2019, 1700 hours

1.6. Canvassing or offer of an advantage or any other inducement by any person with a view to influencing acceptance of a bid is an offence under Laws of India. Such action will result in the rejection of bid, in addition to other punitive measures.

1.7. Each tenderer shall submit only one bid, either by himself or as a partner in a joint venture or as a member of consortium. If a bidder or if any of the partners in a joint venture or any one of the members of the consortium participate in more than one bid, the bids (of both the individual and the partnership/consortium/joint venture) are liable to be rejected.

1.8. The bidder shall bear all costs associated with the preparation and submission of his bid and IITPKD shall in no case be responsible or liable for those costs, regardless of the conduct or outcome of the tender process.

1.9. The Tender Document is not transferable. The bidder shall make a copy of the tender document before submitting the same to the concerned office. No requests will be entertained for making a copy after the submission of the document.

1.10. IITPKD will respond to any request for clarification or modification of the Tender Document that are received up to **FIVE (05) days** prior to the deadline for submission of bids prescribed by IITPKD. For this purpose, the prospective bidder(s) requiring clarification in the Tender Document shall notify IITPKD in writing at the address mentioned. Any such clarification, together with all details on which the clarification had been sought, will be published in the website.

1.11. Except for any such written clarification by the Institute, which is expressly stated to be an addendum to the tender document issued by the Registrar, IIT Palakkad, no written or oral communication, presentation or explanation by any other employee of any of the Sections/Departments of the Institute, shall be taken to bind or fetter the Institute.

2. AMENDMENTS IN THE TENDER DOCUMENT

2.1. At any time prior to the deadline for submission of bids, IITPKD may, for any reason, whether at its own initiative or in response to a clarification requested by a prospective Bidder, modify the Tender Document by way of amendment(s).

2.2. Amendments will be intimated through the institute's website and the tenderers shall ensure that the amendments are carried out in the bid before submission. The amendments will not be published in newspapers. Bidders should regularly visit the institute's website to keep themselves updated.

2.3. No extension in the bid due date/ time shall be considered on account of delay in receipt of any document by mail. Further, it will be assumed that the Bidder has taken into account, such amendments, while submitting the bid.

3. COMPOSITION OF THE TENDER DOCUMENT

3.1. The Tender Document comprises of:

(a) Instruction to the bidders including terms and conditions

(b) Schedule of Quantity (Annexure-I)

(c) Pre-qualification Criteria (Annexure-II)

(d) Techno-Commercial Parameters (Annexure-III)

(e) Commercial Bid (Annexure-IV)

(f) Compliance Statement (Annexure-V)

(g) Format of Performance Security (Annexure-VI)

(h) Declaration (Annexure-VII)

(i) Fall Clause Notice Certificate (Annexure-VIII)

(j) Guarantee For Furnishing (Annexure-IX)

3.2. The bidder is expected to examine all instructions, forms, terms and conditions in the Tender Document. In the event of discovery of any missing pages, the bidder shall inform the same to the Section/ Department concerned. Failure to furnish the information required by the Tender Document or submission of a tender not substantially responsive to the Tender Document in every respect will be at the bidder's risk and may result in rejection of the bid.

3.3. The bidder shall not make or cause to be made any alteration, erasure or obliteration to the text of the Tender Document.

4. LANGUAGE/FORMAT/SIGNING OF THE BID

4.1. The bid prepared by the Bidder and all correspondence and documents related to the tender exchanged by the Bidder and IITPKD shall be in English and the Contract shall be construed and interpreted in accordance with that language. If any of the brochures, leaflets or communication is prepared in any language other than English, a translation of such document, correspondence or communication shall also be provided at the cost and risk of the bidder. The translation so provided shall prevail in matters of interpretation. The bidder, with respect to such documents, correspondence and communications, shall bear the costs and risks of such translation.

4.2. The documents comprising the bid shall be typed or written in indelible ink and all the pages shall be signed by the bidder or a person or persons authorized by the bidder. All the pages of the bid shall be numbered and except for unamendable printed, shall be signed by the person or persons authorized.

4.3. The bid shall not contain any internalizations, erasures, overwriting, except to correct errors made by the bidder, in which case the person or persons signing the bid shall initial such corrections with date.

5. DOCUMENTS COMPRISING THE BID

5.1 The Technical and the Financial Bids shall be sealed by the bidder in separate covers duly superscribed as **Furnishing of Computational Imaging and Computer Architecture Lab , at Workshop 3, Transit Campus of IIT Palakkad** and both these sealed covers are to be put in a bigger cover, which should also be sealed and duly superscribed as **Furnishing of Computational Imaging and Computer Architecture Lab , at Workshop 3, Transit Campus of IIT Palakkad, Tender No. IITPKD/EWD/MB/053/2019-20**. The financial bid shall not be enclosed with technical bid. The technical details of the Item should be kept inside the Technical Bid envelope and sealed. If the bigger cover is not sealed and marked as required above, IITPKD will assume no responsibility for the bid's misplacement or premature opening.

5.2. Bids must either be spiral bound/stapled together. No loose sheets will be accepted. All pages must be serially numbered.

5.3. **The bidder shall furnish, as part of the bid, an EMD (Earnest Money Deposit) of Rs.12,480/- in the form of an Account Payee DD/Fixed Deposit Receipt/Bank Guarantee from a nationalised bank in an appropriate format, in favour of INDIAN INSTITUTE OF TECHNOLOGY PALAKKAD PAYABLE AT PALAKKAD** along

with the Tender Document. EMD shall be put in a separate sealed cover and duly superscribed (as was done for the technical/commercial bids). **It should not be enclosed either with Technical Bid or with Financial Bid. It shall be ensured by the supplier that the EMD amount is exactly as mentioned above and NOT on the actual price quoted. In case of the EMD amount being LESS than what is specified above, the bid shall be summarily rejected by the Institute.**

5.3.1. Bids not accompanied by the EMD shall be rejected/disqualified.

5.3.2. Photo/FAX copies of the Demand Draft/Banker's pay orders will not be accepted.

5.3.3. No interest will be paid for the EMD.

5.3.4. EMD of the unsuccessful bidders will be returned to them at the earliest after expiry of the final bid validity and latest by the 30th day after the award of the contract.

5.3.5. EMD of the successful bidder shall be returned on receipt of the prescribed Performance Security and after signing of the contract agreement.

5.3.6. EMD shall be forfeited, if the bidder withdraws his bid during the period of validity of the tender.

5.3.7. EMD shall be forfeited, if the successful bidder refuses or neglects to execute the contract or fails to furnish the required Performance Security within the time frame specified by the Institute.

5.3.8 If a bidder is MSME/NSIC registered supplier then they will be exempted from submitting EMD for the tendered items. The Bid submitted without EMD in the prescribed format or valid NSIC/MSME certificate of exemption for the tendered items will not be accepted.

5.4. Documents establishing conformity of the terms and conditions of the Tender Document shall be provided along with the bid. The offer/bids should be sent only for a system or item that is available in the market and supplied to a number of customers. A list of customers in India and abroad with details must accompany the quotations. Quotations for a prototype machine will not be accepted.

5.5. Original catalogue (not any photocopy) of the quoted model duly signed by the principals must accompany the quotation in the Technical bid. No prices should ever be included in the Technical bid.

5.6. Compliance or Confirmation report with reference to the specifications and other terms and conditions should also be obtained from the principal.

5.7. Information related to the agency/bidder such as photocopies of the Registration/PAN/GST/TIN shall be furnished.

5.8. The technical bid should consist of all technical details along with commercial terms and conditions. No prices should be included in technical bid. Financial Bid should indicate item-wise prices for the items mentioned in the technical bid.

5.9. Bidders, who are bidding for this NIT shall,

(i). have documentary evidence (Purchase Order/ Work Order) of having executed at least one order of **"Furnishing of Labs"** to a **Centrally/State Funded Institution**. The bidder must provide a certificate of satisfactory performance of the supplied items from the institute to which they have recently supplied. Contact details of the faculty In-charge of the installed setup must be provided.

(ii). Have an Annual Turnover of Rs.19 Lakh during each of the last three financial years (2016- 17, 2017-18, 2018-19). The bidder shall enclose the audited statements of the indicated financial years, which should have been certified by a Chartered Accountant . IT Returns for the financial years indicated above shall be enclosed

5.10. Copy of Tender Document marked "Original" with each page signed and stamped to acknowledge acceptance of the same.

6. BID PRICES

6.1. Prices must be quoted separately for each item identified.

6.2. Price quoted for item must include all costs associated with packing, transportation, insurance, delivery of material, taxes (separately), loading and unloading on DOOR DELIVERY basis to the institute including its installation, commissioning, integration and validation.

6.3. Prices quoted by the bidder shall remain fixed during the validity of the bid.

7. BID CURRENCY

7.1. Prices of the items shall be quoted in Indian Rupees.

8. CONFORMITY OF THE TENDER DOCUMENT

8.1. The Bidder shall furnish, as part of its bid, documents establishing the conformity of the item that the Bidder proposes to supply under the Contract to the requirements of the Purchaser, as given in the Tender Document.

8.2. The documentary evidence of conformity of the item to the Tender Document may be in the form of written descriptions supported by literature/diagrams/certifications, including:

(a) A detailed description of the essential technical, functional and performance characteristics of the Furniture / Hardware that the Bidder is proposing to supply;

(b) Technical details of the major subsystems/components of the item;

9. PERIOD OF VALIDITY OF BIDS

Bids shall remain valid for a period of **180** days after the date of deadline for submission of bids prescribed by the Purchaser.

10. MODIFICATION AND WITHDRAWAL OF BIDS

10.1. The Bidder may modify or withdraw the bid after submission, provided a written notice of the modification or withdrawal is received by the Purchaser prior to the deadline prescribed for bid submission.

10.2. The Bidder's modifications shall be prepared, sealed, marked and dispatched in an envelope duly marked BID MODIFICATION.

10.3. A Bidder wishing to withdraw the bid shall notify the Purchaser in writing prior to the deadline prescribed for bid submission. The withdrawal notice shall:

(a) be addressed to the Purchaser at the specified address and

(b) bear the reference number and the title of the project, and the words BID WITHDRAWAL NOTICE. Bid withdrawal notices received after the bid submission deadline will be ignored and the bid submitted prior to that will be deemed to be a valid bid.

10.4. No Bid shall be modified subsequent to the deadline for submission of Bids.

10.5. No bid shall be withdrawn in the interval between the bid submission deadline and the expiration of the bid validity period. Withdrawal of a bid during this interval shall result in the forfeiture of the Bidder's EMD.

11. OPENING AND EXAMINATION OF BIDS

11.1. The Technical bids will be opened on the prescribed date and time as mentioned in the Bid document. Bidders or their representative may be present during the opening of technical bid, if they wish to be present.

11.2. The purchaser will evaluate the technical bids. Those bids, whose technical bids fulfill the technical requirements and responsive to the tender requirements will be considered. Those bids which found to be either non-responsive, not satisfying the technical requirements or both will not be considered and will be rejected.

11.3. The Price bids of the successful bidders on the basis of evaluation as mentioned in will be considered for the next stage for opening.

11.4. The Purchaser will examine the bids to determine whether they are complete, whether any computational errors have been made, whether required security has been

furnished, whether the documents have been properly signed and whether the bids are generally in order.

11.5. Arithmetical errors will be rectified on the following basis. If there is a discrepancy between the unit price and the total price, which is obtained by multiplying the unit price and quantity, or between subtotals and the total price, the unit or subtotal price shall prevail and the total price shall be corrected. If there is a discrepancy between words and figures, the amount in words shall prevail. If a Bidder does not accept the correction of errors, the bid will be rejected and its EMD may be forfeited.

11.6. The Purchaser may waive any minor non-conformity or irregularity in a bid that does not constitute a material deviation, provided such waiver does not prejudice or affect the relative ranking of any Bidder.

11.7. Prior to the detailed evaluation, the Purchaser will determine whether each bid is complete and is substantially responsive to the Tender Document. For purposes of this determination, a substantially responsive bid is one that conforms to all the terms, conditions and specifications of the Tender Document without material deviations, exceptions, objections, conditionality or reservations. A material deviation, exception, objection, conditionality, or reservation is:

(a) One that limits in any substantial way the scope, quality, or performance of the item;
OR

(b) One that limits, in any substantial way that is inconsistent with the Tender Document, the Purchaser's rights or the successful Bidder's obligations under the Contract: and

(c) One that the acceptance of which would unfairly affect the competitive position of other Bidders who have submitted substantially responsive bids.

11.8. If a bid is not substantially responsive, it shall be rejected by the Purchaser and may not subsequently be made responsive by the Bidder by correction of the non-conformity.

The Purchaser's determination of bid responsiveness will be based on the contents of the bid itself and any written clarifications submitted by the Bidder.

12. CLARIFICATION OF BIDS

During the bid evaluation, the Purchaser may, at its discretion, ask the Bidder for a clarification of its bid. The request for clarification and the response shall be in writing, and no change in the price or substance of the bid shall be sought, offered or permitted.

13. EVALUATION OF RESPONSIVE BIDS

The Purchaser will evaluate the bids that have been determined to be substantially responsive.

14. CONTACTING THE PURCHASER

14.1. From the time of bid opening to the time of Contract award, if any Bidder wishes to contact the Purchaser on any matter related to the bid, it shall do so in writing.

14.2. If a Bidder tries to directly influence the Purchaser or otherwise interfere in the bid evaluation process and the Contract award decision, his bid shall be rejected.

15. AWARD CRITERIA

15.1 Purchaser will award the Contract to the Bidder, whose bid has been determined to be substantially responsive and evaluated as the lowest quote.

15.2. The Institute reserves the right to buy different items/quantity from different bidders considering price of individual/group of item or any other factors as decided by the Committee.

16. PURCHASER'S RIGHT TO ACCEPT/REJECT BIDS

16.1. The Purchaser reserves the right to accept or reject any bid or to annul the bidding process and reject all bids at any time prior to Contract award, without thereby incurring any liability to the Bidders.

16.2. The Purchaser reserves the right to negotiate with the Bidder, whose bid has been evaluated as the lowest quote.

17. AWARD OF PURCHASE ORDER

17.1. Prior to the expiration of the period of bid validity, the Purchaser will issue the Letter of Intent / Purchase Order to the successful Bidder in writing.

17.2 The Purchase Order will constitute the foundation of the Contract.

18. CONTRACT AGREEMENT

18.1. Within **SEVEN (07) days** of receipt of the Purchase Order, the successful Bidder shall sign and date its copy on each page and return it to the Purchaser, along with the Performance Security.

18.2. Copy of Purchase Order duly signed and dated by the successful Bidder on each page shall constitute the Contract Agreement.

19. PERFORMANCE SECURITY

19.1. Within **FIFTEEN (15) days** of receipt of notification of award from the Purchaser, the successful Bidder shall furnish the performance security equal to 5% of the Contract value (excluding the value of annual maintenance charges). The Performance Security shall be valid all along the warranty period and shall extend upto sixty (60) days after the date of completion of warranty period.

19.2. The performance security shall be a bank guarantee (in the format as provided in **Annexure-VI** of the bidding documents) issued by any Scheduled Bank in India acceptable to the Purchaser or a Demand Draft favouring, **INDIAN INSTITUTE OF TECHNOLOGY PALAKKAD** payable at PALAKKAD.

19.3. The performance security shall automatically become null and void once all the obligations of the Supplier under the Contract have been fulfilled, including, but not limited to, any obligations during the Warranty Period and any extensions to the period. The performance security shall be returned to the Supplier not later than fifteen (15) days after its expiration.

19.4. Failure of the successful Bidder to comply with the requirements shall constitute enough grounds for the annulment of the award and forfeiture of the EMD, in which event the Purchaser may make the award to the next lowest evaluated bid submitted by a qualified Bidder or call for new bids.

20. CONTRACT DOCUMENTS

20.1. All documents forming part of the Contract (and all parts of these documents) are intended to be correlative, complementary and mutually explanatory. The Contract shall be read as a whole.

20.2. The order of precedence of the Contract documents shall be as follows:

- (i) Contract Agreement
- (ii) All other Forms
- (iii) Furniture/Hardware and their requirements
- (iv) Supplier's Bid
- (v) Tender Document

21. AMENDMENT TO CONTRACT

No amendment or other variation of the Contract shall be effective unless it is in writing, is dated, expressly refers to the Contract and is signed by a duly authorized representative of each party to the Contract.

22. SUPPLIER'S RESPONSIBILITIES

22.1. The Supplier's obligations involve:

- (a) Supply of items given in Tender Document.
- (b) Making operational, the item (installation, commissioning, testing and validation of the furniture / hardware).
- (c) Development of test methods and applications.
- (d) Training, at the cost of Supplier, of personnel in operation, day-to-day maintenance and troubleshooting of the item.
- (e) Supply of Material (instruction/operation/service/maintenance manuals including drawings & circuit diagrams and application notes), Calibration Certificates (where applicable, traceable to national/international standards) and any other documents specified in the Contract.

22.2. The Supplier shall, unless specifically excluded in the Contract, perform all such work and/or supply all such items, services and materials not specifically mentioned in the Contract but that can be reasonably inferred from the Contract as being required for installation, commissioning, integration and validation of item as if such work and/or items and materials were expressly mentioned in the Contract.

22.3. The Supplier shall comply with all laws in force in India. The laws will include all national, provincial, municipal or other laws that affect the performance of the Contract and are binding upon the Supplier. The Supplier shall indemnify and hold harmless, the Purchaser from and against any and all liabilities, damages, claims, fines, penalties and expenses of whatever nature, arising or resulting from the violation of such laws by the Supplier.

23. TIME FOR SUPPLY, INSTALLATION, COMMISSIONING AND VALIDATION OF THE ITEM

23.1. The Supplier shall supply the item within the period specified in the tenderdocument i.e. within FOUR weeks of signing the purchase order or within the period mutually agreed between purchaser and supplier.

23.2. The Supplier shall thereafter proceed with the installation, commissioning, integration and validation and demonstrate operational acceptance of the item within the period specified. The item shall be installed and commissioned by the successful bidder within 20 to 25 days from the date of its receipt.

23.3. The tenderer should indicate clearly the time required for delivery of the item. In case there is any deviation in the delivery schedule, liquidated damages clause will be enforced or penalty for the delayed supply period will be levied.

23.4. In the event of failure of supply of the item within the stipulated delivery schedule, the Purchaser has all the right to purchase the item from other sources on the total risk of the Supplier under the risk purchase clause.

24. TERMS OF PAYMENT

24.1. No Advance payment will be made for purchase. 100% payment will be released after satisfactory delivery, acceptance, installation, commissioning, integration and validation of the item and against the installation report/certification provided jointly by the supplier (technical representative involved in the process of installation) and the user department/facility.

24.2. If any time before the delivery of the material, it is found that the same material had been offered to another party in India at a lower rate, payment shall be restricted to the extent of such lower rate and the Supplier shall be liable to pay the Purchaser the difference in two rates i.e. excess charged over such lower rate, if payment had been made by the purchaser. The purchaser will look into a reasonable past period to ensure this.

25. TAXES AND DUTIES

The Supplier should ensure payment of all taxes, duties, levies and charges assessed by all municipal, state or national government authorities, in connection with the Goods and

Services supplied under the Contract. The custom duty as applicable after considering eligible concessions based on DSIR exemption etc will only be paid by the purchaser. A copy of the DSIR Certificate shall be provided by the purchaser upon request, for customs duty exemption.

26. PENALTIES

26.1. If the Supplier fails to complete any of the activities in accordance with the time specified for it, or any extension of the time granted by the Purchaser, the Supplier shall pay to the Purchaser, penalties at the rate specified in the Tender document.

26.2. The Purchaser reserves the right to terminate the contract if the Supplier defaults on any of the time limits by more than FOUR weeks.

27. DEFECT LIABILITY

27.1. The Supplier warrants that the item, including all sub-assemblies and components provided, shall be free from defects in the design, engineering/manufacturing, workmanship and performance that prevent the item and/or any of its sub-assemblies and components from fulfilling the requirements or that limit in a material fashion the operation, reliability, accuracy, sensitivity and precision of the item, its sub-assemblies and components. Commercial warranty provisions of products supplied under the Contract shall apply to the extent that they do not conflict with the provisions of this Contract.

27.2. The warranty period shall commence from the date of validation/installation of the furniture and hardware and shall extend for the length of time specified in the tender document supra.

27.3. If during the warranty period any defect found in the furniture, the Supplier shall promptly, at its sole cost, repair or otherwise make good such defect as well as any damage to the furniture/hardware caused by such defect. Any defective furniture, sub-assembly or component that has been replaced by the Supplier shall become the property of the Supplier and the new substituted/replaced material in good condition shall become the property of the purchaser.

27.4. Validation of the furniture/hardware shall be carried out by the Supplier each time a major repair is carried out in the material during the warranty period.

27.5. Response time for attending to defects shall be 24 to 48 hours, after they are reported to the Supplier or its designated service agent. If the material cannot be used for more than TWO working days by reason of such defect and/or making good of such defect, the warranty period for the material shall be extended by a period equal to the period during which the material could not be used by the Purchaser because of such defect and/or making good of such defect.

28. WARRANTY AND INDEMNITY

28.1 The Supplier hereby shall indemnify and hold harmless the Purchaser from and against any and/or losses, liabilities and costs (including losses, liabilities and cost incurred in defending a claim alleging such a liability), the Purchaser may suffer because of any infringement or alleged infringement of any Intellectual Property Rights.

28.2 The offer should clearly specify the warranty or guarantee period for the items. Any extended warranty offer from the same shall be mentioned separately.

29. EFFECT OF FORCE MAJEURE

29.1 If the Supplier is prevented, hindered, or delayed from or in performing any of its obligations under the Contract by an event of Force Majeure, then it shall notify the Purchaser in writing of the occurrence of such event and the circumstances of the event of Force Majeure within ONE WEEK after the occurrence of such event.

29.2. The Supplier, when affected by the event of Force Majeure shall use reasonable efforts to mitigate the effect of the event of Force Majeure upon its performance of the

Contract and to fulfill its obligations under the Contract, but without prejudice to Purchaser's right to terminate the Contract.

29.3. No delay or non-performance by the Supplier caused by the occurrence of any event of Force Majeure shall:

(a) Constitute a default or breach of the Contract;

(b) Give rise to any claim for damages or additional cost or expense occasioned by the delay or non-performance.

29.4. If the performance of the Contract is substantially prevented, hindered, or delayed for a single period of more than THIRTY days or an aggregate period of more than SIXTY days on account of one or more events of Force Majeure, the Purchaser shall have the right to terminate the Contract by giving a notice to the Supplier.

30. EXTENSION OF TIME LIMITS FOR SUPPLY AND MAKING OPERATIONAL, THE ITEM

The time limit for supply, installation & commissioning, integration & validation shall be extended if the supply is delayed or impeded in the performance of any of its obligations under the Contract by reason of any of the following:

(a) Any occurrence of Force Majeure;

(b) Any other matter specifically mentioned in the Contract;

By such period as shall be fair and reasonable in all the circumstances and as shall fairly reflect the delay or impediment sustained by the Supplier.

31. ASSIGNMENT

The Supplier shall not, without the prior written consent of the Purchaser, assign to any third party, the Contract or any part thereof.

32. GOVERNING LAW

The Contract shall be governed by and interpreted in accordance with the laws of India.

33. SETTLEMENT OF DISPUTES

Any dispute or claim arising out of/relating to this Contract or the breach, termination or the invalidity thereof, shall be settled by the Hon'ble Courts of Justice at Palakkad.

34. The page number should be marked in all pages serially (including all supporting documents enclosed with the tender document) and the declaration for the same shall be submitted by the bidder as in **Annexure-VII**.

35. IITPKD reserves the right to accept or reject any or all the tenders in part or whole or may cancel the tender at its sole discretion without assigning any reason whatsoever. No further correspondence in this regard will be entertained.

REGISTRAR

ANNEXURE-I

I. Name of Supply :Instrument table for center for computational imaging" and "computer architecture lab" in workshop 3 of transit campus,IIT Palakkad

Sl No	Description of item	Quantity	Unit	Rate	Amount
1	Table of size 1200mm (L)x700(W)x 900 mm (H)made of 18 mm Polished granite top (black) and MS Powder coated support structure as per drawing	12	each		
Specification:-					
Sl No.	Part used	Description			
1.1	Table top	18 mm Polished black colour granite all edge moulded.			
1.2	Table top dimension				
	Length	1200 mm			
	Width	700 mm			
	Thickness	18 mm polished granite.			
1.3	Under structure as per the drawing attached	4 no's MS powder coated section of 50 x 50 x 2.06 mm for legs .(Overhang around for table top frame shall be 30 cm) Tie member around 40 x20x1.6 mm top around and two short side at bottom.			

II. Name of Work: PhD Scholars table for computational imaging" and "computer architecture lab" in workshop 3 of Transit campus.

Sl No	Description of Item	Quantity	Unit	Rate(Rs)	Amount
1.	PhD Scholars table for computational imaging" and "computer architecture lab" in workshop 3 of transit campus. Size :1200mm x750mm x750 Height as per the drawing attached below	16	nos		
A	Table Top :25 mm thick prelaminated Particle Board conforming to IS : 12823 (exterior grade) with 2 mm PVC edge banding				
B	Front Side Cover: -18 mm thick prelaminated Particle Board conforming to IS : 12823 (exterior grade) with 2 mm PVC edge banding 480 mm high x 450 mm long (curved shape)				
C	1 No Back cover 480 mm high made out of 18 gauge CRCA sheet including fixing to				

	table frame				
D	2 Nos Side cover 700 mm high,300 mm wide made out of 18 gauge CRCA sheet including fixing totable top frame.				
E	Under structure: 50 mm x50 mm x2.1 mm thick CR pipe for leg and support frame under the table top.				
F	Top tray: 1200 mm x300 mm wide made out of 18 gauge CRCA Sheet				
G	Table should be provided with following electrical and net work facility i.5A 3 pin Universal Socket -3 Nos per table ii. 2 Ethernet Socket Ports one per table				
2	Supply of Mobile pedestal consist of mobile Drawer unit with three drawers made up of 18mm thick pre-laminated particle board conforming to IS : 12823 (exterior grade) for side,top,bottomand drawers with center locking facility,full open type telescopic slide for drawers. The pedestal units are made mobile with the use of castors suitable for 80 kg load with lock mechanism. The drawer units are provided recessed handle and suitable lock. Pedestal unit should have cushion at top 100 mm thicknes,density not less than 50 kg/m3 size 450x400 mm on the top of the mobile pedestal unit. Mobile pedestal of size- 450 mm(L) x 400mm(W) x550 mm(H)	16	nos		



III. Name of Supply : Visiting Chair for Transit campus

SI No	Description of item	Quantity	Unit	Unit Rate(Rs)	Amount(Rs)
1	Supply of visiting chair of over all size:118cm high ,58cm width with following specification and as per photo attached	16	nos		
	Base:The 640 mm dia five pronged base shall be made out of nylon – Reinforced with bottom metal ribbing for additional buttress and strength. To conform ANSI/BIFMA X5.1-2011 General Purpose Office Chair Standards				
	Castors:Castors - Twin Castors 50mm dia wheel made of Nylon castors conform to ANSI /BIFMA X 5.1 – 2002				
	Gaslift:-Class 4 conform to ANSI BIFMA performance standards				
	Seating Structure: Seat shall be made out of 12mm moulded hot pressed plywood in ergonomic shape fitted with high quality T - nuts and riveted in to the wood				
	Upholstery: Cushion with high density cold cured self skinned pre moulded foam of 52 kg/cum density in the shape of plywood. Hardness -- 12.6kgf at 25%				
	Synchro Mechanism:This mechanism manufactured out of cold Rolled Carbon Steel IS 513-1994 Sheets,The steel components shall be manufactured with highly precision tools for accuracy in matching other parts for smooth functioning. The steel components shall be fabricated by using Co2 welding process for giving uniform surface finish with higher tensile strength. Springs are made out of Grade II material. Composite release levers for locking mechanism & Gas lift height adjustment. The lever locks in upright and also in 17degree at maximum tilting position. Release lever mechanism for Locking and Gas lift height				

	adjustment. The mechanism shall be lockable in zero (front) position				
	Tension Control:Tension control shall be given below the side fixed with mechanism, Active, telescopic, rotating motion				
	One Way Armrest: Moulded self skinning polyurethane arms confirming with steel inserts for long life and maintenance free usage. Using international styling moulded self skin, Polyurethane, metal inserts for durability, comfort and long life. PU Arms shall have density of 350 to 450 gm/ltr, for smooth finish aberration and scratch resistance and easy maintenance				
	Back: Should have Mesh Back on Frames				
	Fabric: Seat should be upholstered with approved fabric (Response Shade) which shall be Fire retardant & conform to BS EN 1021-1:1994 (Cigarette) BS 7176 : 1995 Low Hazard standards				
	Seat: Depth-46 cm Width- 49.5 cm Minimum Seat Height- 45 cm Maximum Seat Height- 55.5 cm Width (Arm to Arm)- 46 cm Arm Rest Height- 62.5 cm				



PRE-QUALIFICATION CRITERIA FOR BIDDERS

Only those bidders fulfilling the following criteria should respond to the tender.

1. The bidder should be a company registered under the Companies Act, 1956/2013 OR a Limited Liability Partnership / a registered partnership firm OR a sole-proprietorship entity. Appropriate Registration incorporation certificate must be submitted.
2. The bidder must be in existence in the business of **Furnishing of Lab costing not less than Rs.6 Lakh per annum** for a minimum period of three previous financial years (2016-17, 2017-18 and 2018-19). Documentary evidences of experience must be provided.
3. The bidder should have executed at least one order of **Furnishing of Lab** during previous three financial years (2016-17, 2017-18 and 2018-19). Copies of the most recent purchase orders and certificates of successful implementation must be included.
4. The bidder must provide detailed specification of each item. Model numbers, data sheets and brochures must be included for each quoted material/accessories/item. Specifications corresponding to quoted model number must be available publicly via OEM's website for scrutiny. If not, bid can be disqualified on technical grounds.
5. Compliance sheet for the technical specification and OEM Brochure have to be attached along with the Technical bid. Vendor has to fill the compliance sheet and mention page number or reference number in OEM brochure. Unfilled / partially filled sheets lead to disqualification.

TECHNO-COMMERCIAL PARAMETERS

(To be enclosed in a separate sealed cover with the Technical Bid)

PART-I

1. Company Profile

- a) Name
- b) Postal address of the registered office
- c) Name & Designation of CEO / Director

- d) Nature of Business (Proprietary / Partnership/ any other mode)

- e) Email ID & Contact number(s) of CEO / Director

- f) No. of years of operations in India

- g) Year of Establishment

- h) Location of offices in India / abroad

2. Alliances for the purpose of this Bid

- a) Details of alliance(s)

- b) Type of alliance(s)

3. Experience/Credentials

- a) No. of similar units installed in India

- b) No. of similar units installed in Karnataka/Tamil Nadu/ Telangana/Andhra Pradesh or Kerala or any other nearby city/town

- c) List of satisfied clients in India

- d) Testimonials from atleast three clients shall be attached

4. Service Support in India

- a) Track record of service provided with supporting documents during last 3 years
- b) Location of service centers

- c) Number of trained service engineers

- d) Number of trained service engineers exclusively dedicated to each material offered

- e) Number of trained service engineers for the material offered stationed in Karnataka/ Tamil Nadu/ Telangana/ Andhra Pradesh or Kerala

- f) Number of application specialists

- g) Whether the OEM makes available any service

- h) Support in India

5. Availability of spares in India

- a) Whether the service set up maintains stock of essential spares in India

- b) Lead time for supply of essential spares

PART-II

1. Name of the Bidder

- a) Postal address
- b) Telex / Fax number
- c) Telephone (Landline)
- d) Mobile No.:
- e) Email address:
- f) Type of firm: Propriety/ Private/ Private Ltd/ MNC/ Cooperative /Govt. undertaking
- g) Name of the Proprietor /Partners
- h) Registration No.
- i) Year of commencement of Manufacturing the item
- j) PAN
- k) TIN
- l) GST Number

2. Details of EMD of Rs. 12480/- as mentioned in Clause No. 5.3

DD No.: _____ Date: _____ Amount: _____ Bank/Branch: _____

3. Total Annual Turnover (2016-2017, 2017-2018 and 2018-2019)

(Documents shall be certified by Competent Authority)

4. Has the firm ever been debarred/blacklisted by any Govt. Organization/Dept.? If 'yes' the details thereof.

Signature _____

Name _____

Designation _____

Date: _____ Place: _____

Seal of Company _____

Note:

1. Compliance Statement to specifications of the material to be provided by the tenderer as in **Annexure-IV**.
2. Quoted model shall be in accordance to the geographical location.
3. All the above details shall be related to the vendor for the items quoted.

FINANCIAL BID**THE PRICES SHALL NOT BE MENTIONED HERE WHEN SUBMITTED AS
A PART OF THE TECHNICAL BID, AS PER THE CLAUSE NO.5.9****(To be enclosed in separate sealed cover)**

1. The price of the material, whose details are available in the **Annexure-I** is to be given in the format mentioned below:

Sl. No.	Scope of Work	Total Cost (INR)
1	Furnishing of Computational Imaging and Computer Architecture Lab at Workshop-3, Transit Campus, IIT Palakkad	
Total Amount		
Applicable GST		
Grand Total		

2. The quote should include a **STANDARD WARRANTY** of **THREE YEARS** from the date of commissioning/installation of the item (**Annexure-IX**).

Note:

- a) Rates quoted shall be exclusive of taxes and duties.
- b) **Breakup shall be provided in Schedule of Quantity in Annexure – I. The total cost to be added after break up.**
-) Taxes and duty component should be mentioned separately.
- c) Maximum educational discount as could be offered should be mentioned.
- d) Price quoted for material must include all costs associated with packing, transportation, Insurance, delivery of material, loading and unloading on **DOOR DELIVERY** basis to the Transit Campus of **IIT Palakkad** including its installation, commissioning, integration, testing and validation. Duties and Taxes must be mentioned separately.
- e) Concessional GST@ 5% shall be paid extra against GOI Notification No. 45 & 47/2017, dated 14.11.2017 against Proforma Invoice.
- f) TDS @ 2% shall be deducted as per CBEC Circular No.65/39/2018-DOR dated 14.09.2018.
- g) Do not quote the optional items or additional items unless otherwise mentioned in the Tender document / specifications.

Signature and Seal of the Bidder

COMPLIANCE STATEMENT**(Part of Technical Bid)**

The vendor shall,

1. Prepare, sign and submit the Compliance Statement of the specification of the item in the format given below along with the technical bid in the company letter head.
2. Submit separate Compliance Statement of specification sheets for each item.
3. Ensure that the component number and heading in the Technical Specifications is clearly mentioned in the document. If there are any deviations from the specifications mentioned by IIT Palakkad, the vendor should clearly indicate the deviations and give reasons for the deviation with proper justification.
4. Provide the technical leaflet/literature/catalogue or any relevant document for all the quoted item to IIT Palakkad. The information provided in the compliance statement without supporting documents will not be considered for the evaluation of the technical bid and will be treated as non-compliance and may lead to the disqualification of the technical bid.
5. Clearly respond to every requirement given in the technical specifications. Lack of clarity may be considered as lack of information and may subsequently lead to disqualification of the technical bid.

Format of Compliance Statement:

Item No.	IIT Palakkad's technical specification of components as given in Annexure-I	Specifications of model quoted by the vendor	Vendor's specification complies with IIT Palakkad's technical specification ? (YES/ NO)	Deviation, if any, to be indicated in unambiguous terms	Page no. of relevant specification for the quoted model in the technical manual/ leaflet

FORMAT OF PERFORMANCE SECURITY

1. This deed of Guarantee made this day of _____ between Bank of _____ (hereinafter called the "Bank") of the one part, and Indian Institute of Technology Palakkad (hereinafter called "the Purchaser") of the other part.
2. Whereas the Purchaser has awarded the contract for Supply, Installation, Commissioning, Integration and Validation of _____ (name of the item) (hereinafter called the contract) to _____ (hereinafter called the Supplier); (Name of the Supplier)
3. AND WHEREAS the Supplier is bound by the said Contract to submit to the Purchaser a Performance Security for a total amount of Rs. _____ (Amount in figures and words).
4. Now, I/we the undersigned, being fully authorized to sign and to incur obligations for and on behalf of and in the name of _____ (Full name of Bank), hereby declare that the said Bank will guarantee the Purchaser the full amount of Rs. _____ (Amount in figures and words) as stated above.
5. After the Supplier has signed the aforementioned Contract with the Purchaser, the Bank is engaged to pay the Purchaser, any amount up to and inclusive of the aforementioned full amount upon written order from the Purchaser to indemnify the Purchaser for any liability of damage resulting from any defects or shortcomings of the Supplier under the Contract mentioned above, whether these defects or shortcomings are actual or estimated. The Bank will deliver the money required by the Purchaser immediately on demand without delay without reference to the Supplier and without the necessity of a previous notice or of judicial or administrative procedures and without it being necessary to prove to the Bank the liability or damages resulting from any defects or shortcomings of the Supplier. The Bank shall pay to the Purchaser any money so demanded notwithstanding any dispute/disputes raised by the Supplier in any suit or proceedings pending before any Court relating thereto and the liability under this guarantee shall be absolute and unequivocal.
6. This Guarantee is valid for a period of thirty six months from the date of signing. (Initial period for which this Guarantee will be valid must be for at least thirty (30) days longer than the anticipated expiry date of warranty period).
7. At any time during the period in which this Guarantee is still valid, if the Purchaser agrees to grant a time extension to the Supplier or if the Supplier fails to complete the work within the time of completion as stated in the Contract, or fails to discharge himself of the liability or damages as stated under Para 5 above, the Bank shall extend this Guarantee under the same conditions for the required time on demand by the Purchaser and at the cost of the Supplier.
8. The Guarantee herein before contained shall not be affected by any change in the Constitution of the Bank or of the Supplier.
9. The neglect or forbearance of the Purchaser in enforcement of payment of any moneys, the payment whereof is intended to be hereby secured or the giving of time by the Purchaser for the payment hereof shall in no way relieve the bank of its liability under this deed.
10. The expressions "the Purchaser", "the Bank" and "the Supplier" herein before used shall include their respective successors and assigns.

In witness whereof I/We of the bank have signed and sealed this guarantee on the _____ day of _____ (Month & Year) being herewith duly authorized.

For and on behalf of the _____ Bank.

Signature of Authority

Name of the Official Name:

Designation:

Stamp/Seal of the Bank:

Signed, sealed and delivered for and on behalf of the Bank by the above named _____ in the presence of:

Witness 1

Witness 2

Signature

Signature

Name

Name

Address

Address

ANNEXURE-VII

DECLARATION

We hereby undertake that there are _____ pages, serially numbered, in the submitted tender including the supporting documents. (Please serially number all the pages including blank page, if any).

We have submitted our principal's exclusive authorization letter which is specific for this tender No. _____ dated _____.

Signature and Seal of the Bidder

FALL CLAUSE NOTICE CERTIFICATE

This is to certify that we have offered the maximum possible discount to you in our Quotation No. _____ dated _____ **(Please do not reveal the prices here, which will lead to outright rejection of your bid).**

The prices charged for the Stores supplied under tender should under no event be higher than lowest prices at which the party sells the items of identical description to any other Govt. organization/PSU's/Central Govt, /State Govt. Autonomous bodies/Central/state Universities/Central/State Educational Institutions, failing which the "FALL CLAUSE" will be applicable. The institute will look into a reasonable past period to ensure this.

In case, if the price charged by our firm is found to be more, **IIT Palakkad** will have the right to recover the excess charged amount from the subsequent/unpaid bill of the supplier.

Signature and Seal of the Bidder

Note:

This letter of authority should be on the letterhead of the quoting firm and should be signed by a person competent and having the power of attorney to bind the same.

GUARANTEE PROFORMA - GUARANTEE FOR FURNISHING

We hereby undertake to provide **36 months Warranty Period** for the items of furniture, which we have installed in the workshop-3, Transit campus, IIT Palakkad as described below:

Furnishing of Computational Lab and Computer Architectural Lab at Workshop-3, Transit Campus

Building: Transit Campus

Location: Palakkad

Client: IIT Palakkad

During the warranty period of **THIRTY SIX (36) MONTHS** from the date of installation, we agree to repair or replace to the satisfaction of the end user and registrar, IIT Palakkad, any or all such work that may prove defective in workmanship materials within that period, ordinary wear and tear (unusual abuse or neglect excluded). In the event of our failure to comply with the above mentioned conditions within a reasonable time of **ONE WEEK**, after being notified in writing, we collectively and separately do hereby authorize the Registrar, IIT Palakkad to proceed to have the defects repaired and made good at our expense and we shall pay the cost and charges thereof, immediately upon demand.

WE ALSO HEREBY UNDERTAKE to demonstrate upon the completion of installation/supply and ensure that all units are functioning satisfactorily.

SIGNATURE OF SUPPLIER

SEAL

Date:

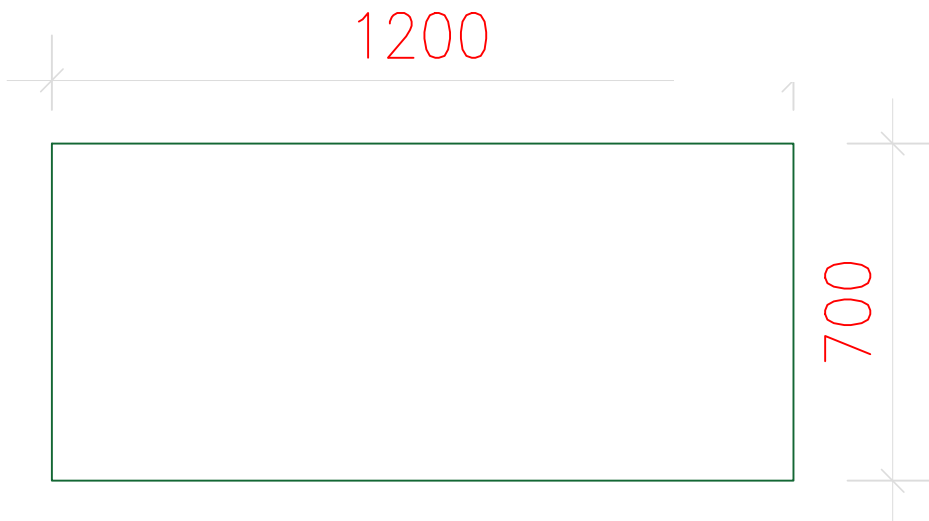

Top View

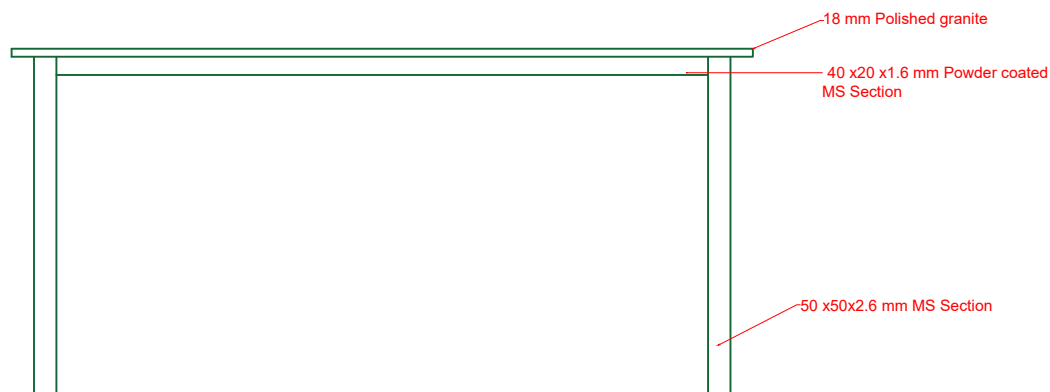

Front View

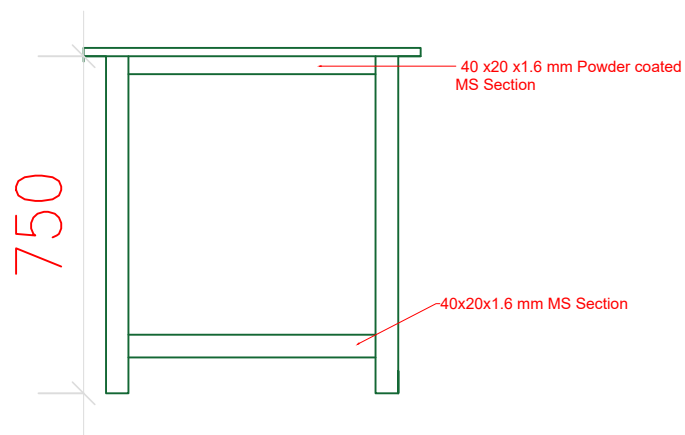

Side View

TABLE FOR Ph.D SCHOLARS

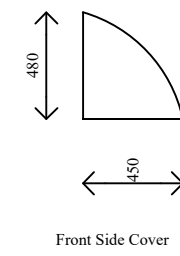
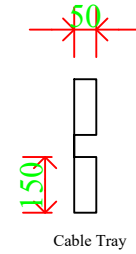
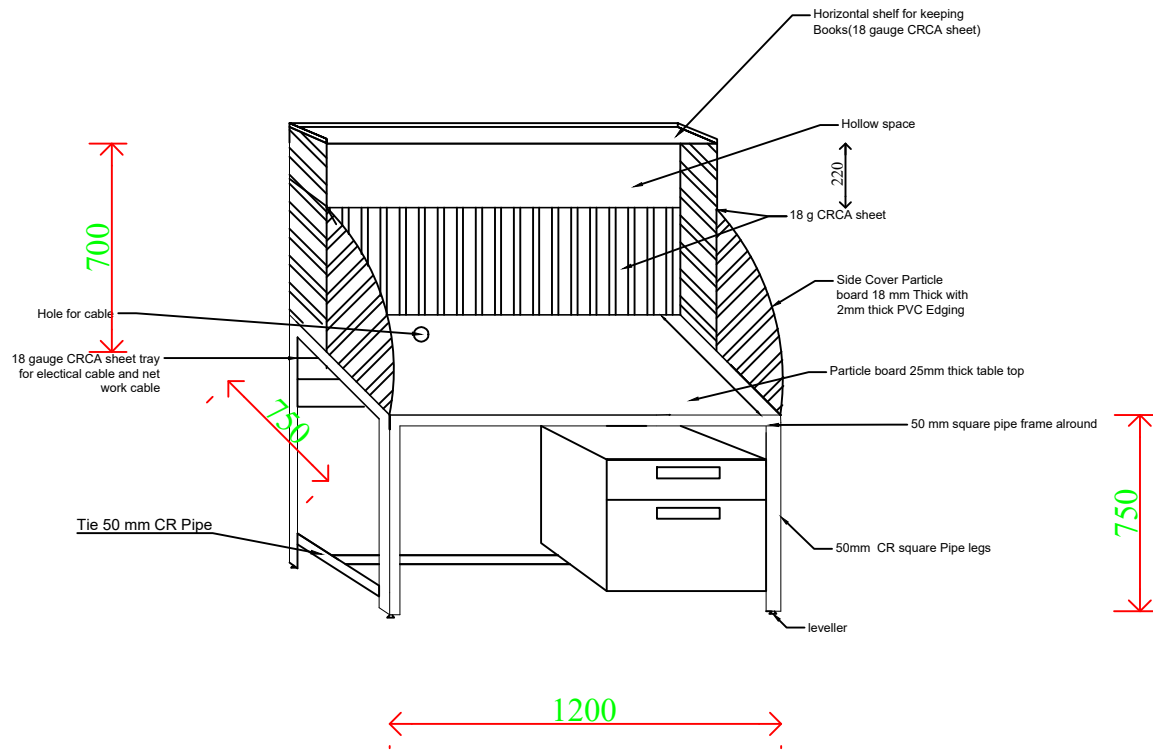

Drawing No.EWD/Cif/01

Prepared by

JE(C)

SPE